

Welding & Cutting Innovations Since 1948.

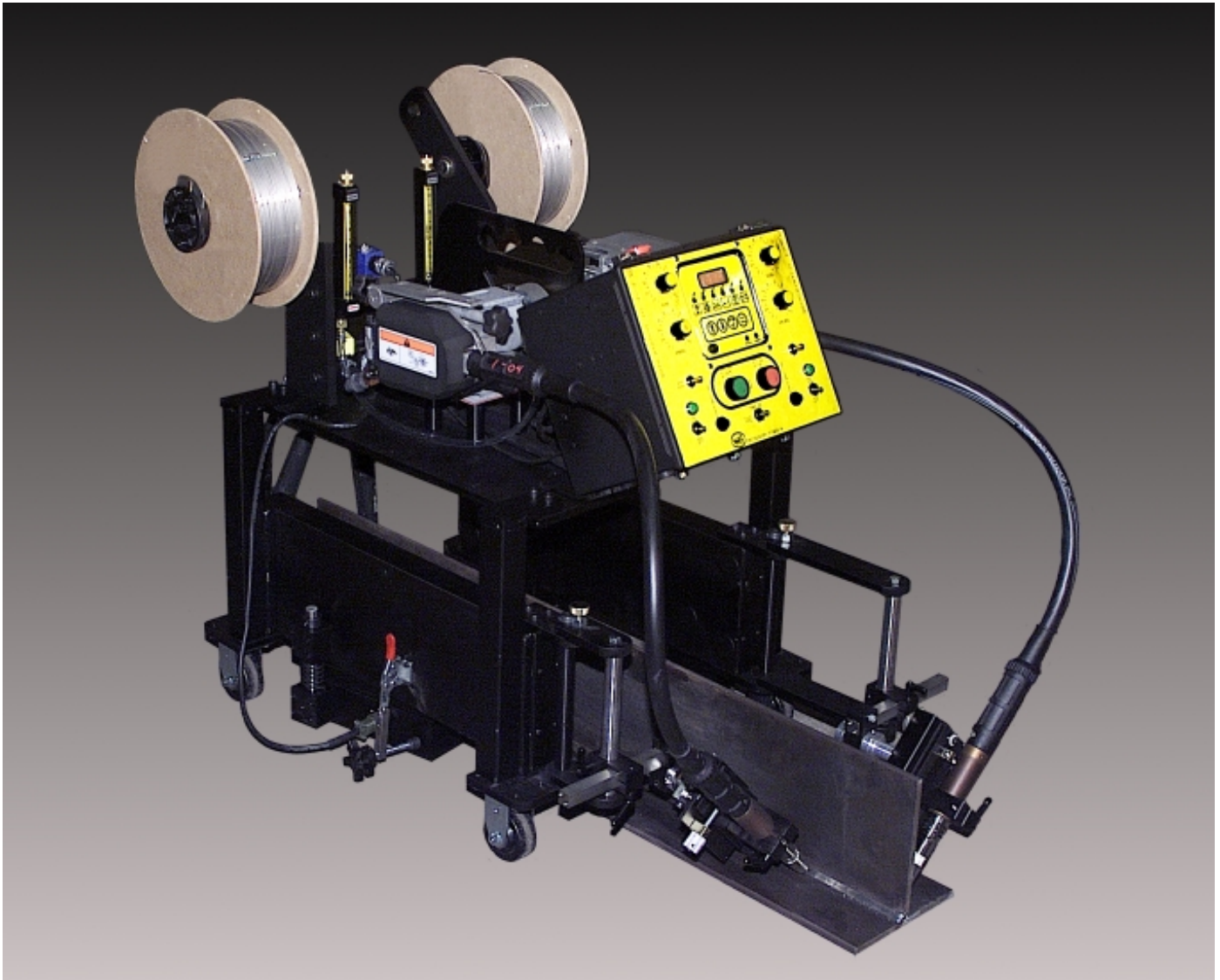

# Dual Sided Fillet Welder Doubles Production.

The Programmable Stiffener Welder will weld both sides of a stiffener at the same time.



The **Programmable Stiffener Welder** is a self-contained, dual head welding travel carriage with integrated wire feeders and spool mounts. It will produce continuous or programmable intermittent fillet welds on stiffeners with heights of 4" to 18" (102-457mm) and widths of 4" to 12" (102-305mm). The unit is self propelled and runs directly on the stiffener. Spring loaded floating torch holders compensate and maintain torch standoff with variations of work piece fit-up. The machine can be used with solid or cored welding wire.



## BUG-O SYSTEMS

A DIVISION OF WELD TOOLING CORPORATION



3001 WEST CARSON STREET PITTSBURGH, PENNSYLVANIA USA 15204-1899  
PHONE: 1-800-245-3186 <http://www.bug-o.com> TELEFAX: 1-412-331-0383



# STIFFENER WELDER

The Programmable Stiffener Welder can accommodate 10, 30 or 60 pound wire reel spools and features independent wire feeder controls for voltage, wire feed speed, cold wire jog and gas purge. When intermittent stitch welding is required the Stiffener Welder features programmable control of weld length and travel speed, skip length, reverse drive crater fill, pre-weld and post-weld gas purge times.

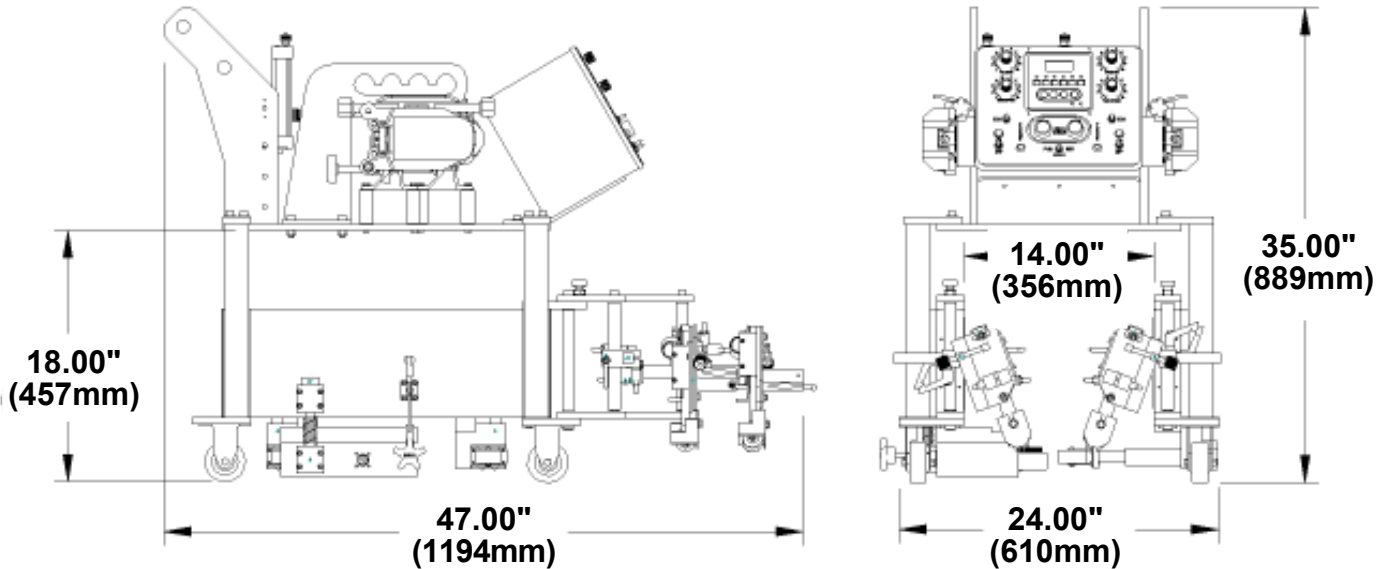

## Technical Data:

Programmable Weld/Skip Travel Speed:	0"-36" ipm (0-900mm/min)
Programmable Reverse Drive Crater Fill:	0"-1" (0-25mm)
Programmable Pre-Weld/Post Weld Gas Purge:	0-10 seconds
Stiffener Size Range:	4"-18" High (102-457mm)
	4"-12" Wide (102-305mm)

